

USER HANDBOOK
FOR
RECEPTION SET R.209 MK.2

CHAPTER I GENERAL DESCRIPTION

1. Purpose and facilities

The R.209 Mk.2 is an 11-valve, high-grade general purpose superheterodyne receiver suitable for tropical use. The Mk.2 is a modified version of the Mk.1 model, the difference being as follows: The 6-volt vibrator pack has been replaced by one using a 12-volt input. The RF amplifier valve (V1) formerly a 1T4 (1.4v.) is now a CV131 (6.3v.) in order to improve the signal/noise ratio. The neon stabiliser (V3) formerly type 9512S has been replaced by the more suitable CV234. The oscillator coils have been modified and compensated in order to achieve better frequency stability. An IF output socket has been provided on the front panel. A fuse has been fitted into the 12v. input circuit and is mounted on the front panel. A dial-lock has been fitted to enable the control to be locked in the tuned position. In performance the set is similar to the R.107 and better than the R.109 receivers and may be used in place of either of them. It can also be used in place of the Reception Sets R.106 and R.206 in cases where lightness is of paramount importance. The receiver can be incorporated in a man-pack, animal or vehicle station and is also suitable as a receiver for high-power senders such as Wireless Sets Nos.12 and 53.

Facilities are provided for receiving E/T (A.M.) CW, ICW and MCW, via rod, open-wire or dipole aeriols. The EM facility, provided with the Mk.1 models, although still available on the system switch, may no longer be efficient since the overall RF/IF gain has been reduced, resulting in possible failure to limit satisfactorily.

Both loudspeaker and headphone output is provided.

The set incorporates its own built-in vibrator power pack driven from a 12v. DC secondary battery.

The receiver is built on the unit principle, consisting of ten separate detachable units, easily removable for servicing.

2. Frequency range

The receiver has a frequency coverage of 1.0 to 20 Mc/s., in four ranges, as follows:-

Range 1	20 Mc/s.	-	12 Mc/s.
Range 2	12.5 Mc/s.	-	5.5 Mc/s.
Range 3	5.6 Mc/s.	-	2.3 Mc/s.
Range 4	2.3 Mc/s.	-	1.0 Mc/s.

The receiver has an IF of 460 kc/s.

3. Power supply and consumption

(1) Inputs (from 12 volt secondary battery)

- (a) Vibrator - 12 volts DC at approx. 1.5 amps.
- (b) LT - 1.4 volts at 650 mA. (except V1 using 6.3v.) via appropriate dropping resistors.

(2) Outputs (from vibrator pack)

- (a) HT1 - 95 volts at 22 mA.
- (b) HT2 - 70 volts at 14 mA. (regulated).

See also Section 8 (14) below.

4. Aerials

Provision is made for low and high impedance aerials to be used with the receiver, matching in at 80 ohms and 1000 ohms, as follows:-

- (a) Dipole (via coaxial line) into 80 ohms.
- (b) Red or wire into 1000 ohms.

5. General construction (See Figs.1, 2 and 3)

- (1) The receiver is built into a ribbed diecast case and its sealed construction renders it waterproof and almost completely airtight.

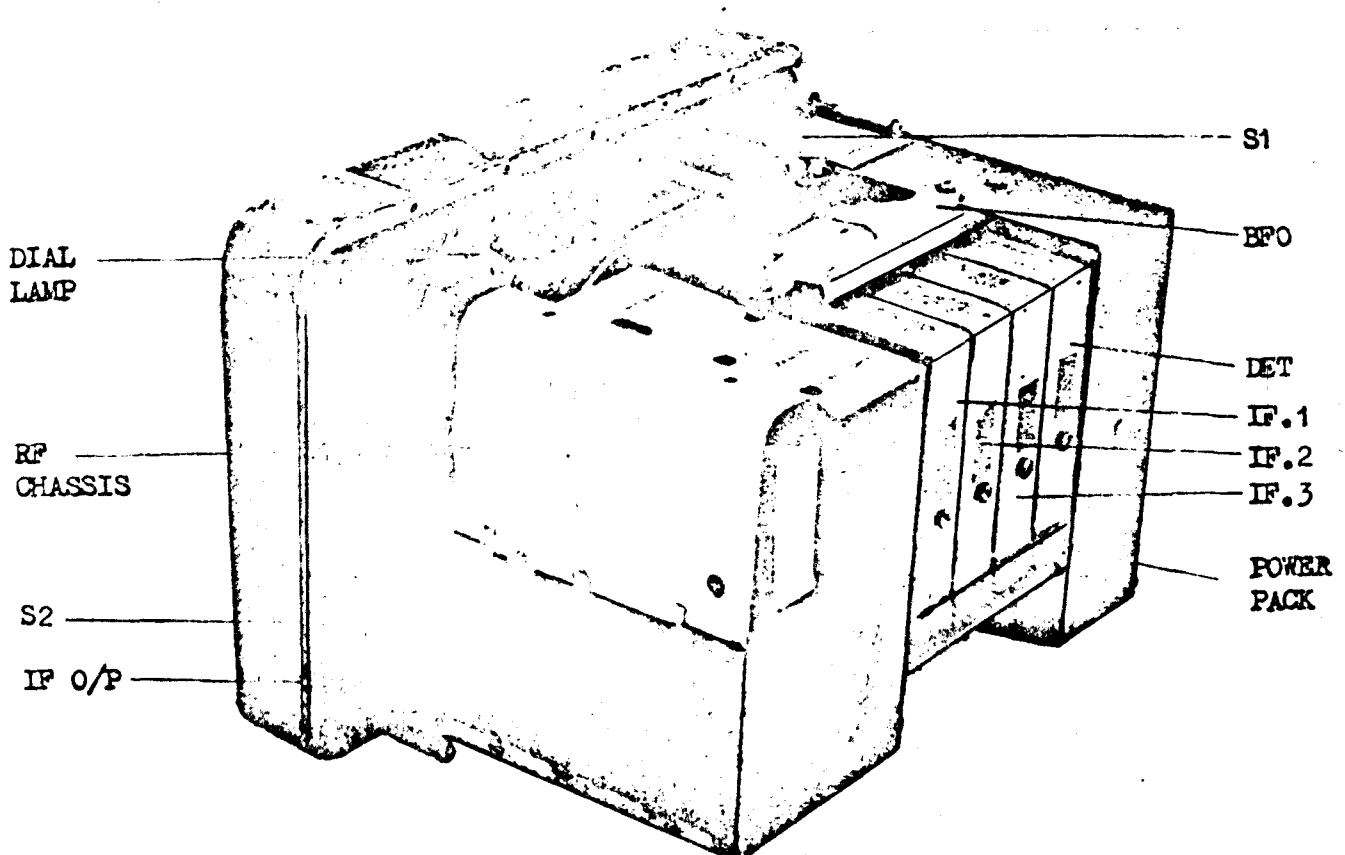

FIG.2 - INTERIOR VIEW OF SET

Its breathing rate is only a few c.c. a day, and any moisture entering is absorbed by the built-in silica gel desiccator. Excess internal moisture causes the gel to change colour from blue to pink. The condition of the gel is viewed through a glass window on the front panel. Miniature technique has been followed throughout in the design of the receiver.

- (2) The receiver incorporates a self-contained vibrator power supply unit driven from an external 12V secondary battery.
- (3) Ten valves and a neon stabiliser are employed in the set which attains high stability by means of a very rigid R.F. chassis and well-constructed condenser drive.

The main tuning condenser scale and drive give a high degree of re-setting accuracy with negligible backlash, the latter being obtained by the use of spring-loaded gears.

- (4) An outstanding feature of the receiver is the unit system of construction which facilitates servicing and routine checks.

Division of sub-units is roughly as follows:-

- (a) Front panel
- (b) R.F. chassis
- (c) 3 I.F. units
- (d) Detector unit
- (e) L.F. chassis
- (f) B.F.O. unit
- (g) Audio chassis
- (h) Power pack
- (j) A separate crash limiter unit which plugs into the front panel

- (5) All controls, terminals and sockets are mounted on a die-cast front panel together with the desiccator holder (Fig. 3(C)), the fuse holder (Fig. 3(B)), and a sealed recess for the loudspeaker (Fig. 3(R)). The panel sealing is provided by a rectangular section Perbunan rubber washer which is housed tightly in a square-section channel round the edge of the panel. The panel is held to the case by 20 fixing screws.
- (6) To achieve rigidity, the foundation of the unit is a robust L-shaped chassis to which all coil units are fixed by strong brackets. The variable condenser is mounted on brackets in a manner which obviates stress on the condenser frame.
- (7) The five plug-in units are each built into a metal case, the leads being brought out to an 8-pin baseplate which plugs into a corresponding socket in the A.F. or I.F. chassis. A foolproof locating pin system prevents a unit being plugged into the wrong socket.

The valves are held in position by sorbo pads and the five units are held by a spring bar fastened across the top of them.

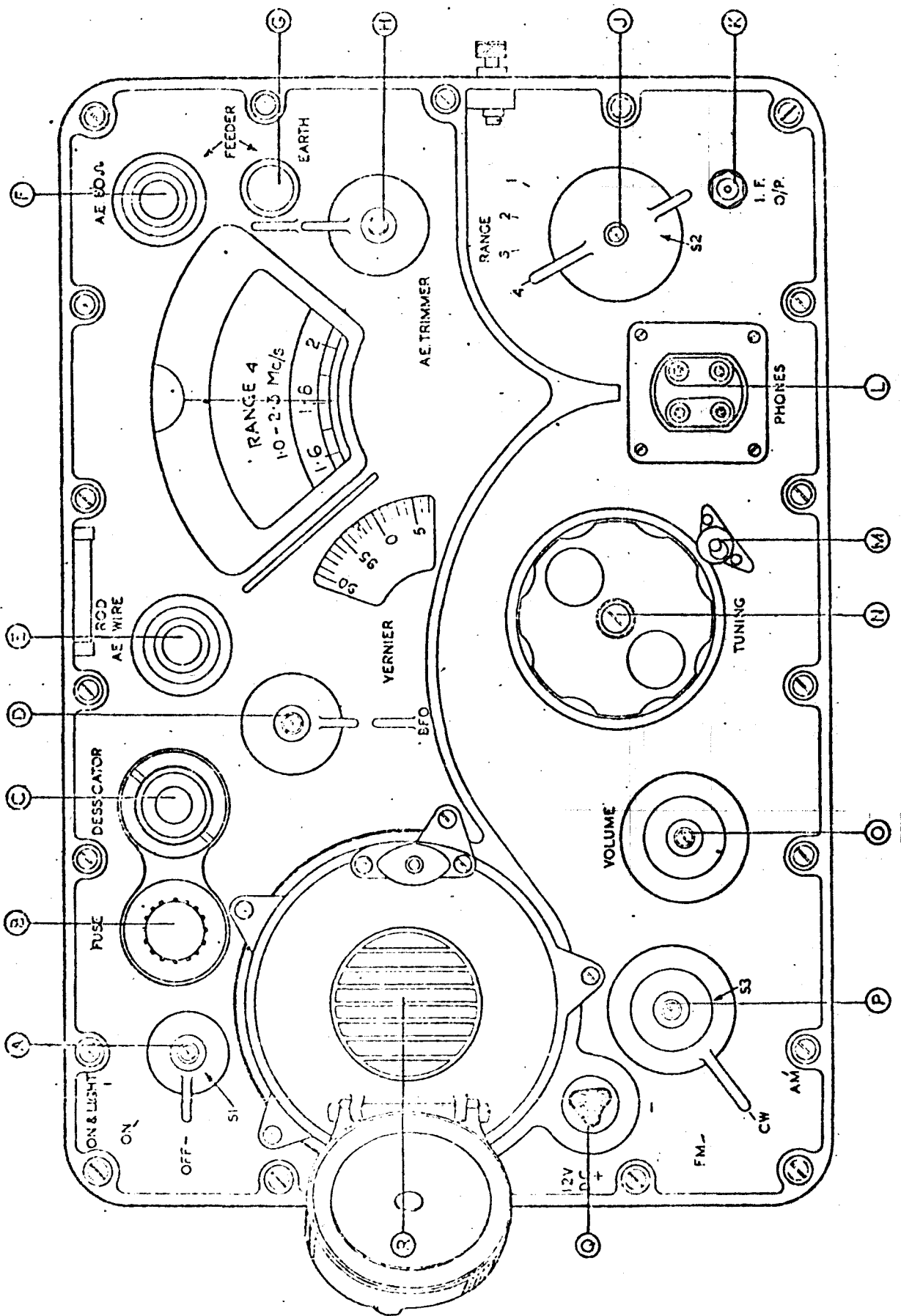

- (8) The I.F. chassis consists of the four 8-pin sockets for the plug-in units and the associated inter-stage wiring.
- (9) The output chassis is a Permalux sheet held by a metal bracket bolted to the front panel, and on it are mounted the output valves and the socket for the B.F.O. unit. The bracket also supports the system switch and the volume control.
- (10) A separate crash limiter unit is used when necessary. This unit plugs into the PHONES socket on the front panel and the headphones are then plugged into the socket on the crash limiter unit. (See Fig. 1)

6. Connections and controls (See Fig. 3)

The following connections and controls are situated on the front panel.

FIG. 3 REF.	CONTROL	FUNCTION
(A)	ON AND LIGHT) ON) (S1) OFF)	A three-position switch. Position 1 switches ON power supply in addition to the tuning scale lamp. Position 2 switches power supply ON only. Position 3 switches power supply OFF.
(B)	FUSE	For 12 volt D.C. input.
(C)	DESICCATOR	For indicating humid conditions of interior of set.
(D)	B.F.O.	Knob for varying the beat frequency note on C.W. working.
(E)	AE ROD WIRE	Push terminal connection for rod or single wire high impedance aerial.
(F)	AE 80 OHM	Push terminal for 80 ohm dipole feeder aerial connection.
(G)	EARTH	Push terminal for earthing chassis or the screen (second) lead of dipole feeder aerial connection.
(H)	AE TRIMER	Knob for final tuning adjustment of the aerial circuit.
(J)	RANGE (S2)	Four-position switch to select range required (see Section 2 above). The frequency coverage of the range in use is indicated on the main dial mask.
(K)	I.F. OUTPUT	Coaxial plug for C.F.S. adapter connection.
(L)	PHONES & CRASH LIMITER	Sockets for 2 pairs of low impedance 150 ohm phones, or for 4-pin plug of crash limiter unit. When latter is used, phones are plugged into sockets on the crash limiter unit.
(M)	DIAL LOCK	Clamp for tuning knob.
(N)	TUNING	Main tuning knob having finger holes for rapid turning. Adjacent to the tuning knob is the thumbscrew "dial lock".
(O)	VOLUME	Gives A.F. gain on R/P (A.M.) Gives R.F. gain on C.W.
(P)	F.M.) C.W.) (S3) A.M.)	Three-position switch to select the type of operation required.
(Q)	12v. D.C.	Three-pin plug for connection to the 12v. D.C. power supply source.

7. Weights and dimensions

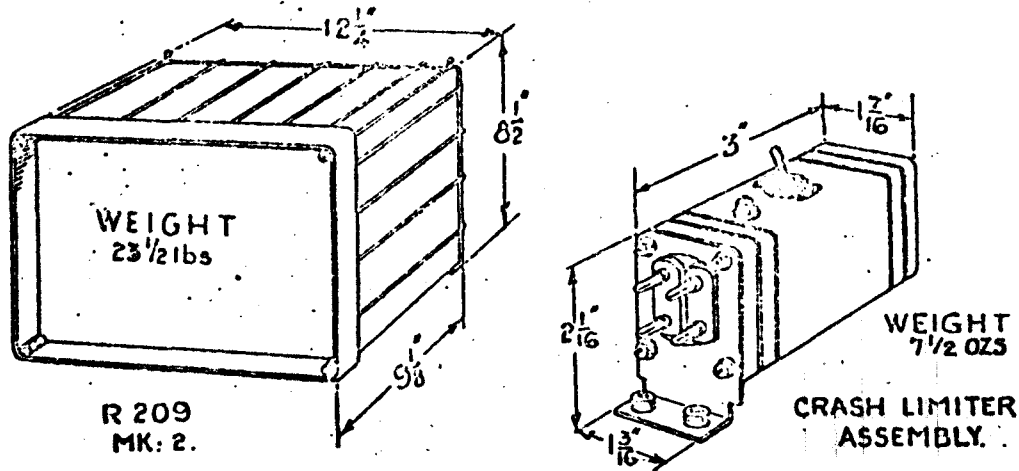

FIG.4 - WEIGHTS AND DIMENSIONS

8. Brief technical description (See Fig. 5)

(1) The R.209 Mk.2 is a high-grade superheterodyne receiver using ten valves plus a voltage stabiliser (V3), as follows:-

V1 - R.F. amplifier	- CV131
V2 - Mixer	- CV782
V3 - Neon stabiliser (Valves electronic)	- CV284
V4 - Local oscillator	- CV785
V5 - 1st I.F.	- CV785
V6 - 2nd I.F.	- CV785
V7 - 3rd I.F.	- CV785
V8 - 2nd Detector on A.M. and C.W.	- CV784
V9 - A.F. output	- CV785
V10 - A.F. output and A.V.C. delay	- CV784
V11 - B.F.O.	- CV784

(2) Aerial input

Provision is made for low and high impedance aerials by the two inputs matching in at 80 ohms and 1000 ohms respectively. To obtain maximum gain in the aerial circuits the inputs are correctly matched to the R.F. tuned circuits by the use of transformer couplings.

(3) R.F. Amplifier

The R.F. amplifier (V1) is a pentode.

The grid circuits are tuned by a section of the 3-gang main tuning condenser. A small variable condenser across the main section is controlled by the knob labelled AE TRIMMER. The latter adjusts the different aerial capacities which may be applied to the set. A.V.C. is applied via the grid leak.

(4) Mixer

The mixer (V2) is a pentagrid. The grid tuned circuits are tuned by the second section of the 3-gang main tuning condenser. An intermediate frequency of 460 kc/s is developed across the tuned primary of the 1st I.F. transformer, the secondary of which is connected to the grid of the 1st I.F. amplifier (V5).

As an additional precaution against frequency shift with change of current drain and subsequent change in voltage, the screen of the mixer valve is supplied from the neon stabiliser.

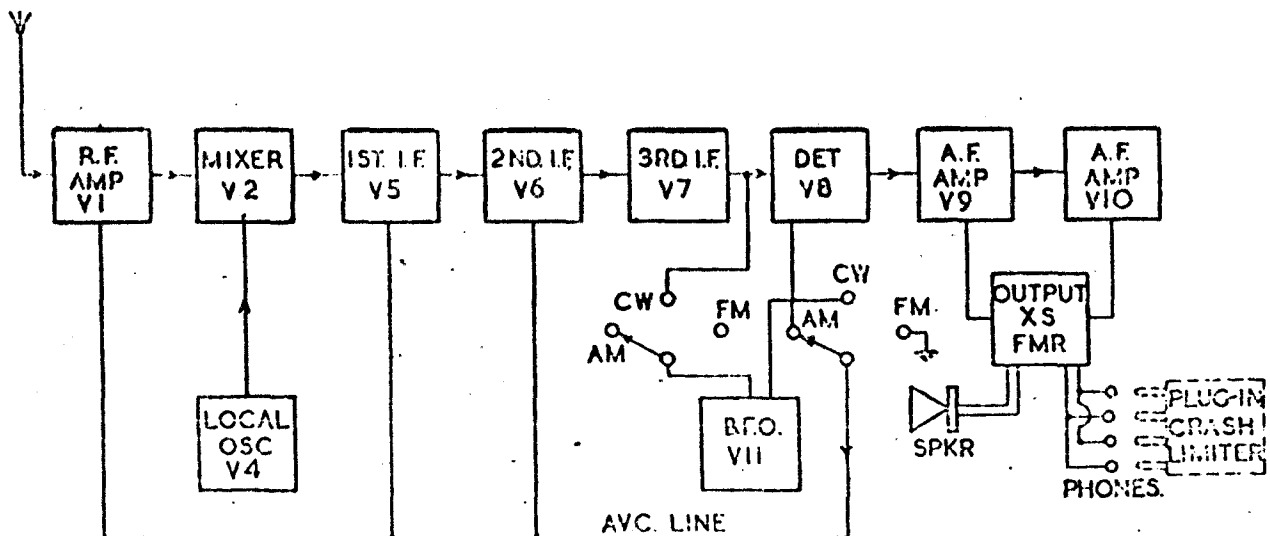

FIG. 5 - BLOCK DIAGRAM .

(5) Local Oscillator

This is a tuned grid reaction oscillator using a pentode (V4) with screen and anode strapped. The required R.F. voltage for mixing is obtained from the grid which is connected directly to the mixer grid. The H.T. to the local oscillator is stabilised by means of the neon (V3) whose working voltage is 66V.

The oscillator coils are tuned by the third section of the 3-gang main tuning condenser.

(6) I.F. Amplifier

I.F. amplification is achieved by three stages employing three pentodes V5, V6 and V7. Each stage is constructed in unit form, housed in an aluminium can mounted on a plug-in base. The three stages are identical. Each I.F. transformer consists of two pairs of cup type iron dust cores, each pair enclosing a coil former. The overall bandwidth is 5 kc/s. at -6 db. A.V.C. is applied to the first two stages only. I.F. is brought out to a concentric plug on the front panel to enable the receiver to be connected to alternative types of detector.

(7) Detector

The detector is a diode pentode (V8). This stage is built into a plug-in metal unit similar to those used in the I.F. stages.

- (a) On R.T. the H.T. is removed from the valve which then acts as a diode detector, the control grid and heater being the rectifying electrodes. The diode load is the volume control variable resistor. A portion of the A.F. voltage is tapped off by the slider of the volume control and is fed to the grid of the 1st output stage (V9).
- (b) On C.W. the valve (V8) is used as for R.T., the beat oscillator (V11) output being injected at the control grid. In this case the A.F. voltage is fed to the grid of the 1st output valve (V9) via a Scott type negative feedback filter.
- (c) On F.M. the H.T. is switched to the anode of the pentode section of V8 which is used as an amplifier limiter and the diode section becomes the discriminator diode. Limiting is achieved by reducing anode voltage, the normal screen voltage being used. Since the overall gain has been reduced in the Mk.2, the F.M. facility will only operate satisfactorily on strong signals.

(8) Beat Oscillator

This stage employs a diode pentode (V11) in a Hartley circuit, the whole being housed in a plug-in case, similar to those used for the I.F. units. The oscillator is tuned over a range of 1.2 kc/s. on each side of the I.F. by the B.F.O. control.

The anode of V11 is electron coupled to the oscillator. The anode output is applied to the diode, which rectifies part of the beat oscillator output, to supply bias to the grids of the R.F. and I.F. amplifiers when the set is working on C.W.

(9) A.V.C.

On A.M. the A.V.C. is obtained from the detector diode load and is applied to R.F. amplifier (V1) and the first two I.F. amplifiers (V5, V6).

On C.W. part of the beat oscillator output is rectified by the diode portion of V11. A portion of this rectified voltage, depending in magnitude upon the setting of the VOLUME control is applied through the slider to the grids of V1, V5 and V6, through the A.V.C. line and to the grid of V7.

(10) Output Stages

Two valves, V9 (pentode) and V10 (diode-pentode) are used for self-drive push-pull output giving approximately 50mW, feeding a 10 ohm loudspeaker and 150 ohm headphones.

(11) C.W. Filter

A Scott type negative feedback filter is used in the output stage to peak-up the beat note on C.W. at an audio frequency of 950 c/s.

(12) Crash Limiter

A separate plug-in unit is provided comprising a full-wave rectifier and an ON/OFF switch. It is connected across the output via a 4-pin plug on the unit, which plugs in to the 4-way PHONES socket of the front panel. In the ON position it reduces sudden interference surges.

(13) Miscellaneous

- (a) Sensitivity 3.5 to 5.0 μ V. for 20 db signal to noise ratio at the 80 ohm input
- (b) Selectivity 4-6 kc/s at 6 db down
 7-13 kc/s at -40 db down
 Cut off slope -6 to -40 db not less than 9 db/kc/s

(14) Power supplies(a) H.T.

The unit employs a built-in vibrator pack driven by a 12 v 1t secondary battery. A selenium type bridge rectifier with extensive filtering and smoothing gives a D.C. output of 22mA at 95 volts and 14mA at 70 volts. Battery consumption is approx. 1.5 amps.

(b) L.T.

Heater current of 650mA is taken direct from the 12 volt input. 200 ohm dropping resistors are used for the directly heated valves on the R.F. deck (V2 and V4), the indirectly heated valve (V1) uses a 50 ohm resistor. All other valves use 220 ohm dropping resistors. Heater voltage is nominally 1.4 volts except for V1 (CV131) which requires 6.3 volts.

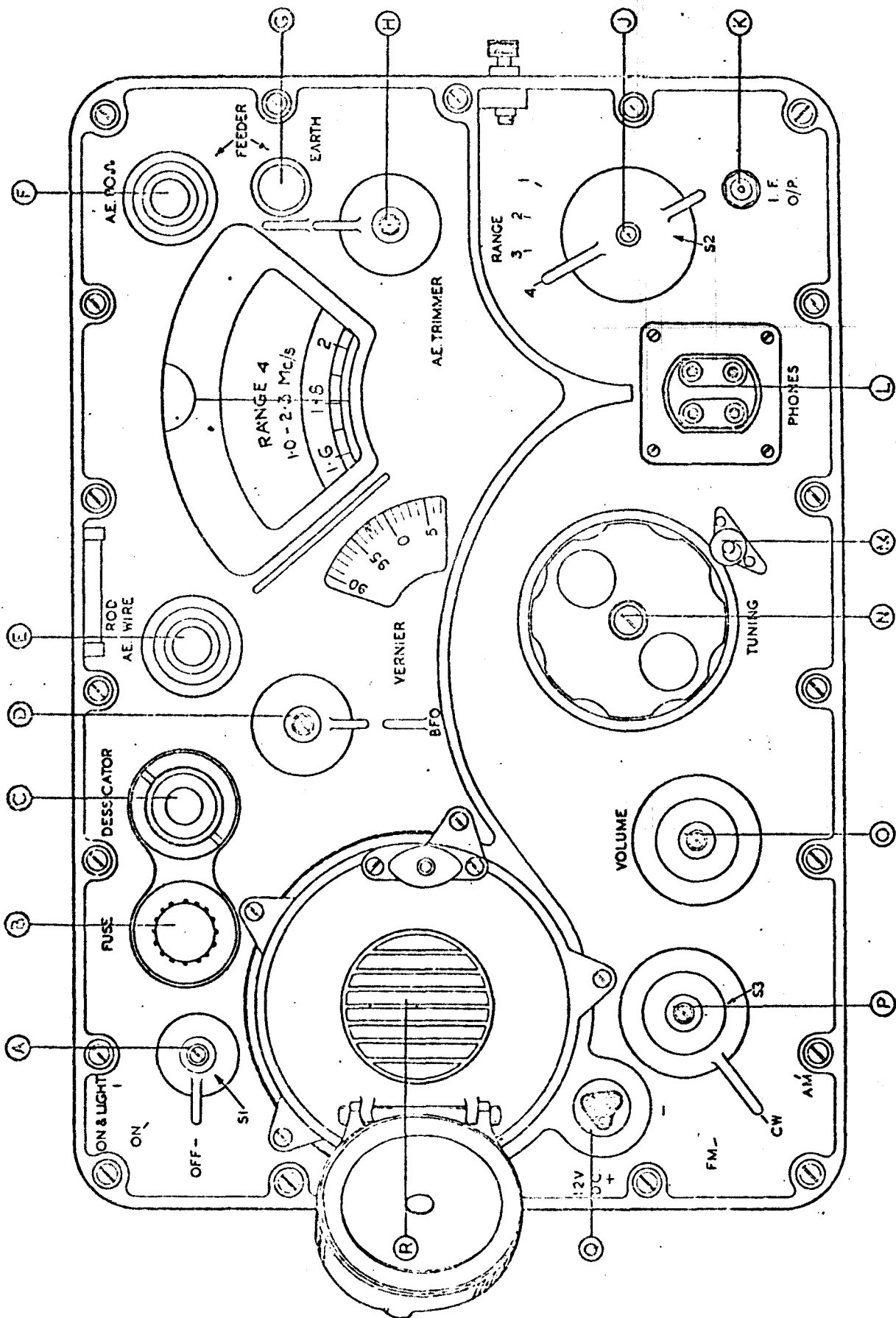

FIG. 3 - FRONT PANEL LAYOUT

9. Preliminary

Before proceeding to operate the receiver make a general mechanical inspection to see that it appears to be in sound condition, and that switches and controls work efficiently.

If installed in a special mounting for use as a man-pack, vehicle or ground station, ensure that the receiver is held securely in its mounting.

10. Setting up (See Fig. 3)

- (1) Connect aerial lead or dipole feeder to the appropriate aerial termination on set, viz. the connecting lead from a vertical rod or a single horizontal wire aerial should be connected to the terminal marked "AE ROD WIRE" (E), and the feeder from a dipole aerial should be connected to the two terminals marked "AE 800 FEEDER", (F) and (G). The smaller of the two latter terminals is also used for the EARTH terminal and the earth lead should be connected to it.

TO CONNECT LEADS TO TERMINALS

A STRIP OFF 1/2 INCH OF THE INSULATION FROM AERIAL LEAD AND CLEAN BARE PORTION.



B PUSH DOWN THE SPRING LOADED TERMINAL TO OPEN THE SLOT.

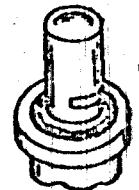

C INSERT BARED PORTION OF LEAD INTO THE OPEN SLOT.

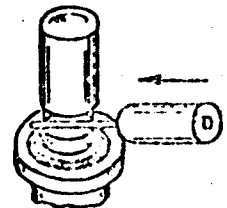

D RELEASE PRESSURE ON TERMINAL ALLOWING SPRING TO CLOSE SLOT.

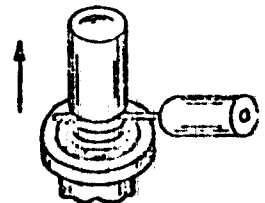

FIG.6

- (2) Set the OFF/ON/OFF & LIGHT switch (S1) (A) to OFF.
- (3) Close the loudspeaker cover (R). Headphones should always be used in normal conditions, as the quality of the loudspeaker output will never be high in the conditions in which it is used in this set.

- (4) Insert phones plug into the PHONES socket (L).
- (5) The crash limiter unit when required is plugged into the 4-way PHONES socket (L), and the 2 pairs of headphones plugged into the sockets on the crash limiter unit. (See Fig.1)
- (6) Set the BFO tuning knob (D) into central position, i.e. with the knob pointer opposite BFO indicator on front panel.
- (7) Insert the 12 volt 3-point socket into the D.C. power input plug (Q).

11. To operate (See Fig. 3)

- (1) Set the RANGE switch (S2) (J) to the number covering the required frequency range. (See Chapter I Section (2) above).
- (2) Set FM-CW-AM system switch (S3) (P) to the required system of operation.
- (3) Switch ON the power supply at source.
- (4) Set OFF/ON/OFF & LIGHT switch (A) to ON (or if illumination of dial is also required, to ON & LIGHT).
- (5) Turn VOLUME control (O) fully clockwise.
- (6) Rotate the main TUNING knob (N) until the required frequency as shown on the calibrated dial is immediately below the hairline on the window.
- (7) Search for required station by turning the TUNING knob (N) slowly in both directions. Screw up (clockwise) DIAL LOCK (M), taking care that dial setting is not disturbed. Finally, adjust AE TRIMMER knob (H) for maximum signal/noise ratio. If a dial re-setting log for various stations has been made for the receiver, tune in any required station by turning TUNING knob (N) until the MAIN and VERNIER calibrated dials give the exact re-setting log readings of the wanted station. Screw up DIAL LOCK (M). Finally, adjust AE TRIMMER knob (H) for maximum signal/noise ratio.
- (8) Turn VOLUME control knob (O) anti-clockwise until signal heard in headphones is at required strength.
- (9) When operating on C.W., after the required station has been located, turn the main TUNING knob (N) until the beat frequency falls to zero (silent point). Screw up DIAL LOCK (M). Then adjust BFO control until the beat frequency note rises to a convenient pitch; the circuit is designed to give peak output at 950 c/s. Finally, adjust AE TRIMMER knob (H) for maximum signal/noise ratio.
- (10) If excessive static is experienced during reception, set the CRASH LIMITER switch (S4) to ON.

12. General

No equipment or installation can be expected to work properly unless it is kept in first-class condition by regular maintenance, conscientiously carried out. This maintenance is the responsibility of the NCO or man who is in direct charge of the equipment and responsible for its operation, NOT of workshop or repair staffs, though workshop personnel may be called upon to carry out certain maintenance tasks.

To guide the NCO or man responsible for maintenance, and to ensure that it is done, it has been laid down that Signal equipment will be maintained on the task system, and that the completion of each task will be recorded on Army Form B.2661 - Unit Maintenance Log.

This Log is reproduced in Appendix I. Completion of maintenance tasks will be recorded by initialling in the spaces provided on the front of the form; all repairs and replacements will be recorded on the reverse. The form lasts 24 weeks, and replacements should be obtained on indent in the normal way. Current and completed forms should be kept in the pocket in the back cover of this handbook.

The maintenance tasks to be carried out daily, weekly and monthly for the equipment or installation are listed in the following sections, which show the full maintenance required for an equipment in continuous use. In conditions where this does not apply, the frequency with which each task is carried out will be detailed by the commander concerned. ACI 1076 of 1945 gives further instructions on the subject.

13. Suggested daily tasks

(1) General

- (a) Keep the set clean. Remove all dust and grease.
- (b) Examine all leads for fraying or abrasion, paying special attention to the points where they enter plugs or sockets.
- (c) See that all plugs and sockets are clean and make good electrical contact. If necessary, slightly open prongs of plug so that they become tight in the socket.

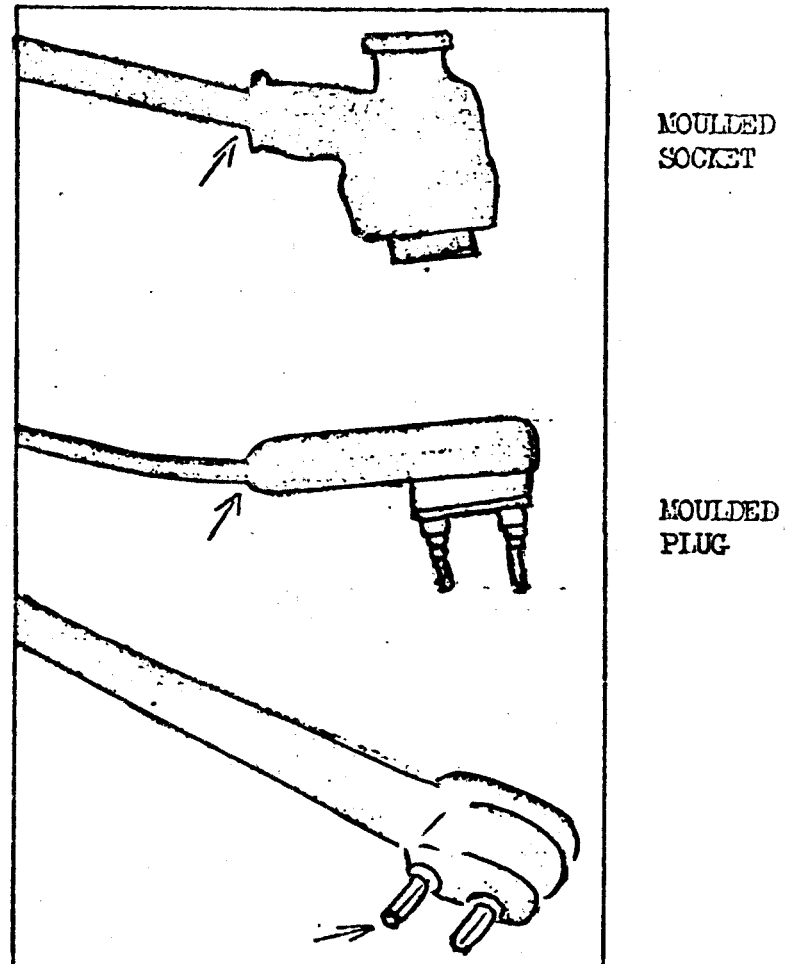

FIG. 7

(2) Batteries

- (a) The condition of batteries should be watched carefully. Re-charging and topping-up require special attention and batteries should be changed immediately this becomes necessary.
- (b) Examine the battery terminals and clean them if necessary, keeping them smeared lightly with vaseline.
- (c) Test the battery voltage with the set switched to ON & LIGHT. The voltage reading should not be allowed to fall below 11.5 volts. If voltage reading is below this figure, the battery should be changed for a new one and the low battery returned for re-charging.

(3) The Receiver

- (a) Check receiver controls and switches to see that they work smoothly and efficiently throughout their range of movement.
- (b) Check that dial lamps switch ON when the switch is set to the ON & LIGHT position.
- (c) Inspect the silica gel desiccator. It should have a blue tint. If the gel is pink, the installed desiccator should be replaced by a spare, making sure that the rubber sealing washer is in good order and giving a tight fit. If the newly installed desiccator also quickly turns pink, it indicates that interior of set is damp or the case is not properly sealed, in which case the set must be returned to workshops for drying and re-sealing.
- (d) Check that receiver performance is normal by listening to signals and background noise.

14. Fault location(1) Sealing

The receiver is hermetically sealed and the operator should not loosen off any of the fixing screws or in any way attempt to remove the set from its case, except when authorised (see paragraph (3) below). Further, none of the control knobs should be tampered with as the spindle sealing glands may become damaged.

(2) Warning

- (a) If, after switching ON, the set does not work, SWITCH OFF IMMEDIATELY.
- (b) Check and ensure that battery, aerial, earth and phones, if used, are properly connected.
- (c) Check again by switching ON. If the set still does not work SWITCH OFF IMMEDIATELY and report matter.

(3) Changing valves, vibrator, etc. (See Figs. 2 and 8)

Where maintenance has to be done which involves opening the set, it should, if possible, be carried out by RCEB. In operational emergency, however, the equipment should be placed in the hands of a radio mechanic. In such a case the procedure is as below.

NOTE: After the set has been opened it must be sent to RCEB as soon as possible for drying out, rechecking and recalibrating

- (a) Remove the set from its case. Remove the securing nuts and bolts from around the edge of the case and gently ease the set out. Count the nuts and bolts (20) and store them in a safe place, (in a tin or box).

NOTE: The interior of the set should be exposed for as short a period as possible. In countries where high humidities are experienced it is best to open the set in the morning while the temperature is rising, rather than in the evening when the temperature is falling and when condensation of water vapour may take place on the interior of the set.

- (b) Vibrator. A faulty vibrator may be the cause of the set being "dead" after it has been switched ON. Remove the power pack screening case by unscrewing the four screws marked (C) in Fig. 8. Plug in new vibrator and replace screening case.

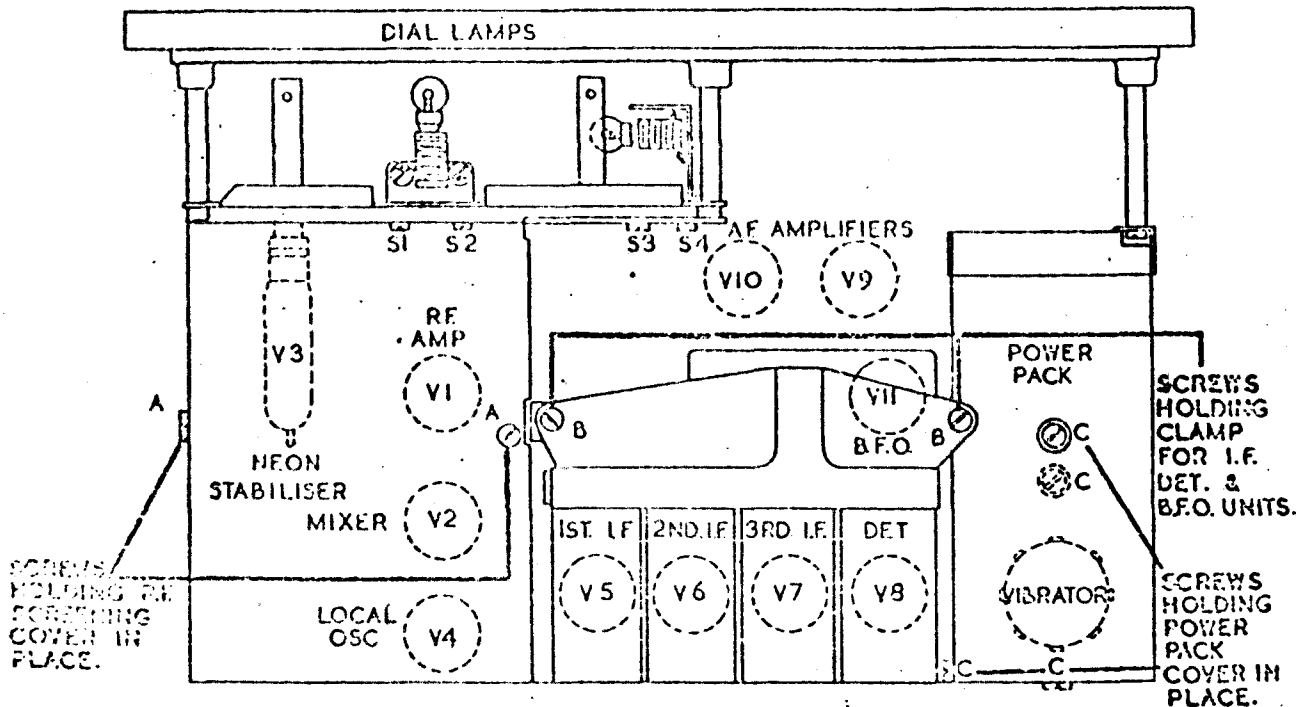

FIG. 8 - PLAN VIEW SHOWING VALVE POSITIONS

- (c) Pilot lamps. If a pilot lamp fails to light while the rest of the set is working, try replacing it with a spare lamp. The main dial lamp and holder can be removed by unscrewing and taking out the two screws S1 and S2 (Fig. 8). The vernier dial lamp and holder are attached to a bracket and to change the lamp the screws S3 and S4 must be removed when the bracket, holder and lamp can be drawn clear. Do not disconnect or put any strain on the leads to lamp holders.
- (d) Valves
- (i) A faulty valve may be the cause of the set not functioning when switched ON. Beginning with V1 try replacing each valve with a new one until set functions. Mark the faulty valve, or valves, and return to stores at the earliest opportunity.
 - (ii) If the local oscillator valve (V4) has to be changed the calibration of the main tuning and vernier scales will become slightly affected. This will cause inconvenience in re-setting since a frequency logged with one oscillator valve cannot generally be re-set on the vernier dial when this valve has been changed. A new dial re-setting log for the working frequencies of the various stations will have to be made.
 - (iii) The H.T. supply to the local oscillator is stabilised by a neon lamp (V3). This should be renewed if it does not glow pink when the set is working. If this neon stabiliser is not working the oscillator drifts and in consequence logging and re-setting frequencies becomes extremely difficult.
 - (iv) The positions of the valves are indicated in Fig. 8. To change the R.F. (V1), mixer (V2), neon stabiliser (V3) or local oscillator (V4) valves, remove the two fixing screws marked (A) at the left of Fig. 8 and take off screening cover. To change an I.F. (V5, V6 or V7), BFO (V11) or DET (V8) valve, remove the two screws marked (B) in Fig. 8, which clamp the units in position. Unplug unit from the chassis and take off the screening can after first removing the fixing screws, one on each of the narrow sides of the can. The valve may then be renewed, and cans and clamping cover, re-fixed in position.
 - (v) The two A.F. valves (V9 and V10), are directly accessible.
- (e) Returning the set to its case. After ensuring that the sealing gasket is fixed in position, carefully fit the set in its case and firmly secure with the 20 nuts and bolts around the edge. Failure to insert or properly tighten up any of these screws will result in moisture getting into the set and subsequently a fault in its working.
- (f) Desiccator sealing ring. This should be replaced by a spare as soon as it shows signs of perishing.

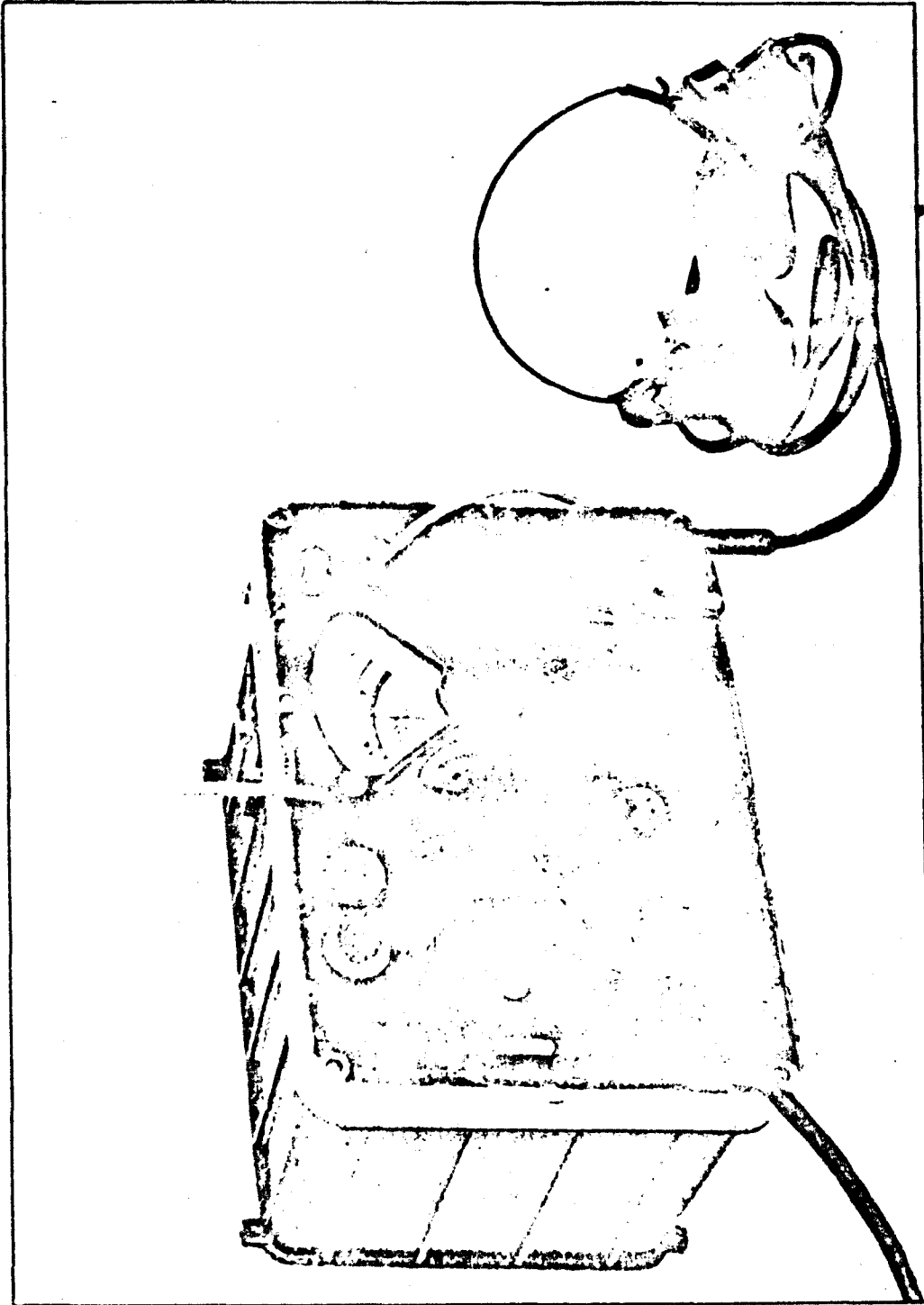

FIG. 1 - R.209, Mk.2, GENERAL VIEW OF SET